



P.O. BOX 490  MARLTON, NEW JERSEY 08053  609/767-6800  FAX: 609/767-3298

MODEL AM-5  
AUTOMATIC MATCHING SYSTEMS  
INSTRUCTION MANUAL







## TABLE OF CONTENTS

|                     |                                       | PAGE |
|---------------------|---------------------------------------|------|
| <u>SECTION I</u>    | DESCRIPTION                           |      |
|                     | General                               | 1    |
|                     | Mechanical                            | 1    |
|                     | Electrical                            | 1    |
|                     | Matching Network                      | 1    |
|                     | Power Supply                          | 2    |
|                     | Detectors                             | 2    |
|                     | DC Sample Network                     | 3    |
| <u>SECTION II</u>   | CONTROLS AND INDICATORS               |      |
|                     | L.E.D's                               | 4    |
|                     | Meters                                | 4    |
|                     | Switches                              | 4    |
| <u>SECTION III</u>  | INSTALLATION                          |      |
|                     | Unpacking                             | 6    |
|                     | Electrical and Mechanical Connections | 6    |
| <u>SECTION IV</u>   | OPERATION                             |      |
|                     | Controls and Indicators               | 7    |
| <u>SECTION V</u>    | AM-5 SET UP                           | 8    |
| <u>SECTION VI</u>   | REMOTE FUNCTION                       | 9    |
| <u>SECTION VII</u>  | REMOTE CONTROL CONNECTIONS            | 10   |
| <u>SECTION VIII</u> | DC METER CONNECTIONS                  | 11   |
| <u>SECTION IX</u>   | ALTERNATE POWER SUPPLIES              |      |
|                     | 115 Volt Operation                    | 12   |
|                     | 220 Volt Operation                    | 12   |
|                     | ±15 Volt DC Operation                 | 12   |
|                     | Optional Line Voltage Schematic       | 12   |
| <u>SECTION X</u>    | TECHNICAL SPECIFICATIONS              | 13   |
| <u>SECTION XI</u>   | RECOMMENDED SPARE PARTS LIST          | 14   |
| <u>DRAWINGS</u>     | D40,247                               |      |
|                     | C30,187                               |      |
|                     | C38,130                               |      |
|                     | D40,289                               |      |
|                     | D44,478                               |      |
|                     | B28,138                               |      |



## SECTION I:

## DESCRIPTION

### GENERAL

#### 1.1

The Automatic Matching Network is designed to transform to the 50 ohms a wide range of resistance and reactive impedances that are encountered during a typical plasma operation. The network design is a basic "L" configuration having a shunt capacitor to handle the loading and a fixed coil and series capacitor to handle the tuning. Both capacitors are driven by servo motors which operate simultaneously and allow instantaneous tuning of the plasma. This tuning procedure is a complete "hands off" operation.

### MECHANICAL

#### 1.2

The equipment is housed in two separate enclosures consisting of a Matching Network/Phase and Magnitude Detector and a Controller/Power Supply which are described as follows:

- The Matching Network is housed in an aluminum enclosure measuring 8 3/4" W x 5" H x 15" D. The Phase and Magnitude Detectors are contained in the Matching Network enclosure.

- The Controller/Power Supply is housed in an aluminum enclosure measuring 1 3/4" H x 8 1/2" W x 10" D, which contains the power supply and control circuitry for operating and controlling the servo motor system.

### ELECTRICAL

#### Matching Network

##### 1.3.1

The Matching Network assembly contains a variable air capacitor, a variable vacuum capacitor and a fixed coil connected in an "L" configuration. The "L" configuration is a widely accepted design because of its ability to allow wide range tuning. The variable capacitors are driven by servo motors.





## Matching Network (continued)

An AUTO-MANUAL-REMOTE switch is provided on the front panel of the controller to select the mode of operation. When in the MANUAL position, momentary switches are provided for manually tuning the network. When in the AUTOMATIC position, the detectors control the speed and direction of travel of the servo motors. When in the REMOTE position an external 0-5 VDC signal controls the position of the motors. The RF input to the network is supplied by a rear mounted "N" panel connector. The RF output is available through a pair of "HN" connectors on the rear panel. There is also an input and output water fitting on the back panel. This is provided to reduce the temperature of the series coil, minimum water flow is 5 G.P.H.

## Power Supply

### 1.3.2

The power supply is completely self-contained providing all necessary circuitry for controlling the servo motor system. The front panel contains the system status lights, TUNE/LOAD position meters and all control function switches. The rear of the power supply contains the Automatic Matching Network connector, the AC line connector and the remote control input/output connector. The power supply can operated from 115 VAC, 220 VAC or  $\pm 15$  VDC @ 1.5 A power source.

## Detectors

### 1.3.3

Both the PHASE and MAGNITUDE detectors are contained within the Matching Network. The PHASE detector controls the TUNING capacitor or series portion of the "L" network. The MAGNITUDE detector controls the shunt capacitor or LOAD portion of the "L" network. Both detectors operate



## Detectors (continued)

simultaneously to transform the impedance of the load to maintain 50 ohms in the transmission line. In essence, when the detectors are sampling 50 ohms in the transmission line, the positive and negative error signals that the detector generates for driving the servo system should be virtually zero. The polarity of the error signal will determine the direction in which the servo motor will travel. This combined with the proper gain of the system will insure the proper tuning sequences.

## DC Sample Network

### 1.3.4

A DC sample circuit is contained within the Matching Network to provide means to measure the developed DC voltage. (See Section VIII for connections and voltage input/output).



## SECTION II

## CONTROLS AND INDICATORS

### L.E.D'S

#### Fail

2.1.1 Indicates a loss of the reference voltage from controller to Matching Network.

#### - Limit

2.1.2 Motor has reached its maximum C.C.W. position.

#### + Limit

2.1.3 Motor has reached its maximum C.W. position.

#### On

2.1.4 Indicates power applied to controller.

### METERS

#### Tune/Load Meter

2.2 Indicates approximate position of TUNE/LOAD capacitor.  
0 = minimum capacitance; 1 = maximum capacitance.

### SWITCHES

#### +/- Switch

2.3.1 Allows capacitance to be increased (+) or decreased (-) in MANUAL mode only.

#### ON/OFF Switch

2.3.2 Applies power to controller.

#### Auto-Manual-Remote Switch

2.3.3 Determines mode of operation. In AUTO, controlling voltage is from Phase and Magnitude detectors. In MANUAL, controlling voltage is from +/- switches. In REMOTE, controlling voltage is from an external 0-5 VDC signal. With switch



## Auto-Manual-Remote Switch (continued)

in REMOTE and a 0-5 VDC signal applied to J2-13 (Load) or J2-12 (Tune) with J2-2 (Load) or J2-5 (Tune) at ground, the TUNE/LOAD capacitor can be pre-set to any position. Removing the ground from J2-2 and J2-5 places the system in AUTO. Capacitor positioning is proportional to applied voltage.

0 VDC = minimum setting

5 VDC = maximum setting

2.5 VDC = 50 percent

J1: Control signals To/From Matching Network.

J2: Remote Input/Output signals.

J3/J4: Not used on AM-5.

(See Sections VI and VII for connections and voltage connections)

## Phase/Magnitude Gain Adjust

2.3.4 Adjusts gain of servo loop.





## SECTION III

## INSTALLATION

### UNPACKING

3.1

Remove the AM-5 Automatic Tuning System from the carton and packing materials. Examine for visible damage. If any part of the system has been damaged notify both RF Plasma Products and the transportation company at once.

### ELECTRICAL AND MECHANICAL CONNECTIONS

3.2

Mount the controller in a convenient rack panel and connect the interconnecting cable and line cord. Remove the cover of the Matching Network and inspect for any loose or broken components. Now connect the interconnecting cable to the jack labeled AMPS-2A (P6) on the Matching Network. Before R.F. is applied a minimum flow of 5 G.P.H. of water is required by the Matching Network. With the AUTO-MANUAL-REMOTE switches in MANUAL operate the  $\pm$  switches making sure the motors turn smoothly and that the limit L.E.D.'s and rotation meters operate. Connect the Matching Network (J3 RF output) to the chamber with a pair of "HN" connectors using RG-217 cable. Mount the Matching Network in position and replace the cover which may have been removed during inspection or mounting. A separate ground strap is required if network is not physically connected to chamber. Next, connect the RF input cable to the rear of the network (J2 RF input).



## SECTION IV

## OPERATION

### CONTROLS AND INDICATORS

4.1

If using an RF Plasma Products RF power supply, turn on the RF power supply to approximately 200 watts or until you have established a plasma. Manually tune the network with the +/- switches on the controller. Once the network has been manually tuned then proceed to position the two toggle switches located on the front of the controller into AUTOMATIC. You will note that in the AUTOMATIC position, the reflected power should be at a minimum position and the forward power at a maximum position consistent with the output of the generator.

To make sure the detectors are tracking properly, switch the controller back into MANUAL and de-tune the Matching Network to approximately 100W reflected power and then flip the toggle switches back into AUTOMATIC. The reflected power should then go back to its original minimum position.

If the network does not seem to be performing in the manner described above, check "AM-5 Set-Up".



## SECTION V

### 5.1

#### AM-5 SET UP

Check that all connections are properly made. Also, check that there is a good ground between chamber, Matching Network, and controller before proceeding. The Matching Network cover must be in place before attempting to null PHASE and MAGNITUDE pots. If network will not tune in MANUAL, try removing one or more of the 200pf ceramic capacitors across A1C1 (Magnitude/Load Capacitor). In some cases it may be necessary to change the number of active turns, (change tap) on the series coil to achieve the best match.

If unit tunes manually but goes out of match in "AUTO", manually retune unit for best match, then place tune in AUTO and with Load still in MANUAL adjust PHASE adjust pot on back of Matching Network for a null in Reflected power. After this is done, place Load in AUTO and tune in MANUAL and adjust MAGNITUDE adjust pot for a null in Reflected power.

After this is done place both TUNE and LOAD switches in AUTO and slightly readjust PHASE and MAGNITUDE adjust pots to improve match if possible.

If motors run to one end before adjustment can be made, manually return to position that gave match originally, then repeat adjustment. In some cases it may help by placing the 10 turn PHASE and MAGNITUDE adjustment pots to the center of their range. If motors "HUNT", try reducing the gain of the PHASE or MAGNITUDE circuit on the back of the controller. C.W. decreases gain. C.C.W. increases gain.

If unit is not sensitive enough to a mismatch, try increasing the gain of the PHASE or MAGNITUDE circuit.



SECTION VI

## REMOTE FUNCTIONS

J2

Pin

|       |                        |                                                         |
|-------|------------------------|---------------------------------------------------------|
| 1     | -15 VDC Input          | (for D.C. operation)                                    |
| 2     | Remote ON/OFF (Load)   | (ground to Enable)                                      |
| 3     | Remote ON (Tune)       | (Low when in Remote)                                    |
| 4     | Remote ON (Load)       | (Low when in Remote)                                    |
| 5     | Remote ON/OFF (Tune)   | (ground to Enable)                                      |
| 6     | - Tune Limit           | (Low at - Limit)                                        |
| 7     | + Tune Limit           | (Low at + Limit)                                        |
| 8     | Failure output         | (Low in normal operation/<br>High with a failure)       |
| 9     | - Load Limit           | (Low at - Limit)                                        |
| 10    | + Load Limit           | (low at + Limit)                                        |
| 11    | Load Meter output      | (0-5 VDC output proportional<br>to Front panel meter)   |
| 12    | Set point input (Tune) | (0-5 VDC input used to position<br>capacitor in Remote) |
| 13    | Set point input (Load) | (0-5 VDC input used to position<br>capacitor in Remote) |
| 14    | +15 VDC input          | (for D.C. operation)                                    |
| 15-22 | Not Used               |                                                         |
| 23    | Tune Meter output      | (0-5 VDC output proportional<br>to Front panel meter)   |
| 24    | Ground                 |                                                         |
| 25    | Ground                 |                                                         |





**SECTION VII:**

**REMOTE CONTROL CONNECTIONS**

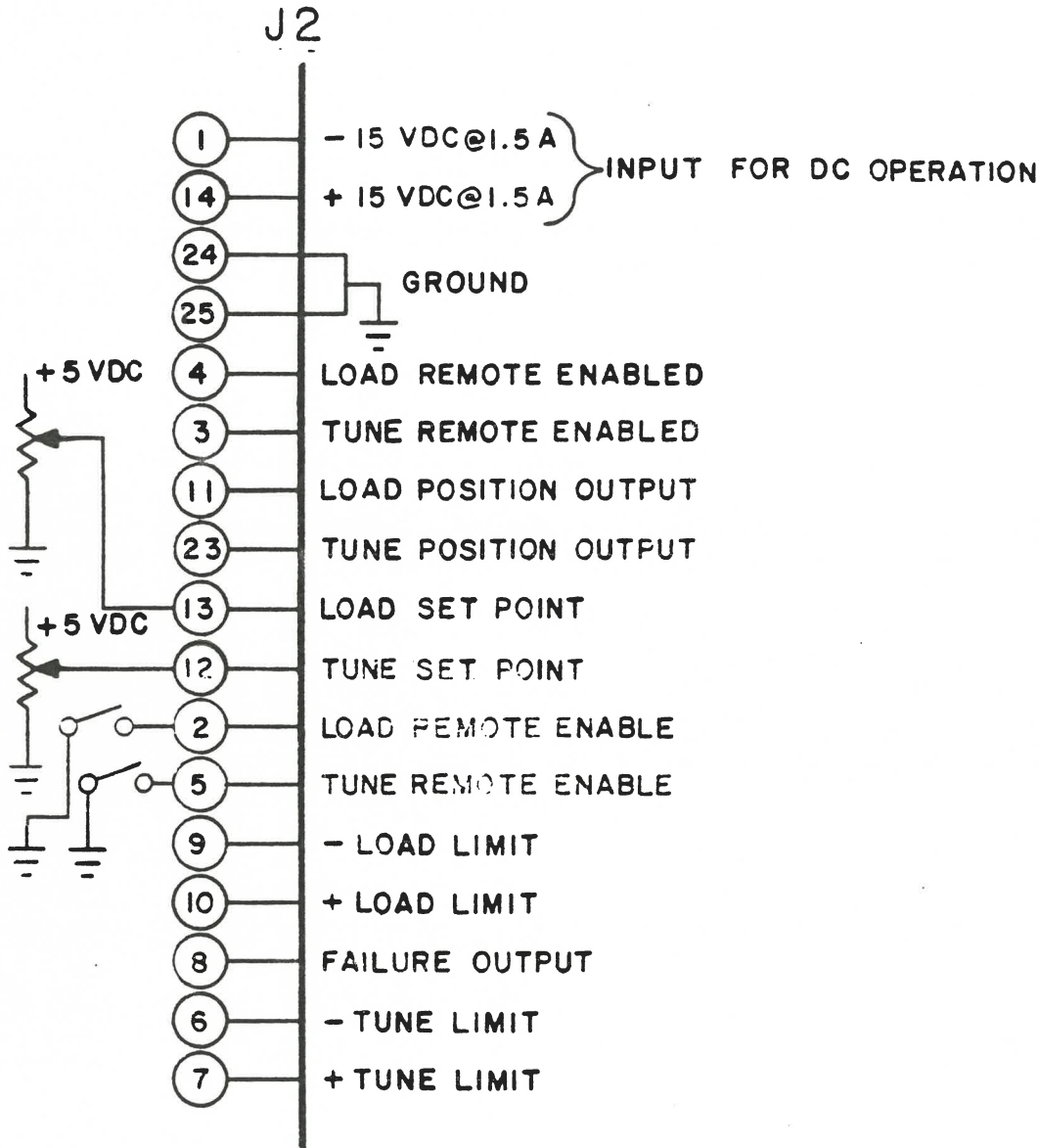

**TYPICAL CONNECTIONS**

(MAX RATINGS 40V/75ma NOT TO EXCEED 200mw PER OUTPUT)

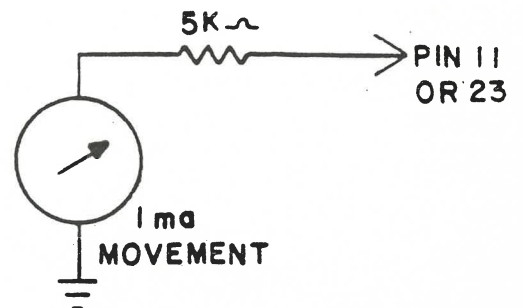
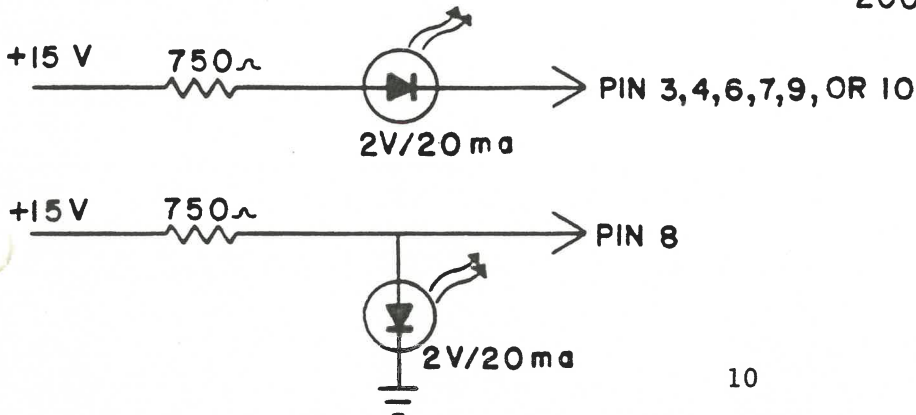



SECTION VIII

DC SAMPLE CONNECTIONS

P7

Pin

- 1 +15 VDC input @ 10 mA
- 2 -15 VDC input @ 10 mA
- 3 No Connection
- 4-5 Ground
- 6-7 No Connection
- 8-9 DC output, Reference to ground (Pins 4-5)

8.1 Voltage output verses voltage input to DC Sample Network.  
(Approximately 1K ohm Load from Pins 8-9 to ground. 1000V  
RF P-P in DC Sampler input).

| Developed DC | DC Sampler Output ( $\pm 2\%$ Accuracy) |
|--------------|-----------------------------------------|
| -50V         | +0.25V                                  |
| -100V        | +0.50V                                  |
| -150V        | +0.75V                                  |
| -200V        | +1.00V                                  |
| -250V        | +1.25V                                  |
| -300V        | +1.50V                                  |
| -400V        | +2.00V                                  |
| -500V        | +2.50V                                  |
| -600V        | +3.00V                                  |
| -700V        | +3.50V                                  |
| -800V        | +4.50V                                  |
| -1000V       | +5.00V                                  |



SECTION IX

ALTERNATE POWER SUPPLIES

115 VOLT OPERATION

9.1 Connect 2 to 3 and 1 to 4 on Transformer T1 Primary. S1 on PC Board must be in position C2. Fuse should be 1 Amp slow blow.

220 VOLT OPERATION

9.2 Neutral (white) line from the AC Input Jack must be run through the second fuse holder. Both fuses will be 0.5 Amp slow blow. S1 must be in position C2. Connect 1 to 3 on Transformer T1 Primary.

±15 VOLT DC OPERATION

9.3 Place S1 to position C1. Apply -15VDC @ 1.5A to J2, Pin 1. Apply +15VDC @ 1.5A to J2, Pin 14. Ground goes to Pins 24 and 25 on J2. Check for +15 Volts on + lead of C10. Check for -15 Volts on - lead of C9 after making the proper change.

OPTIONAL LINE VOLTAGE SCHEMATICS

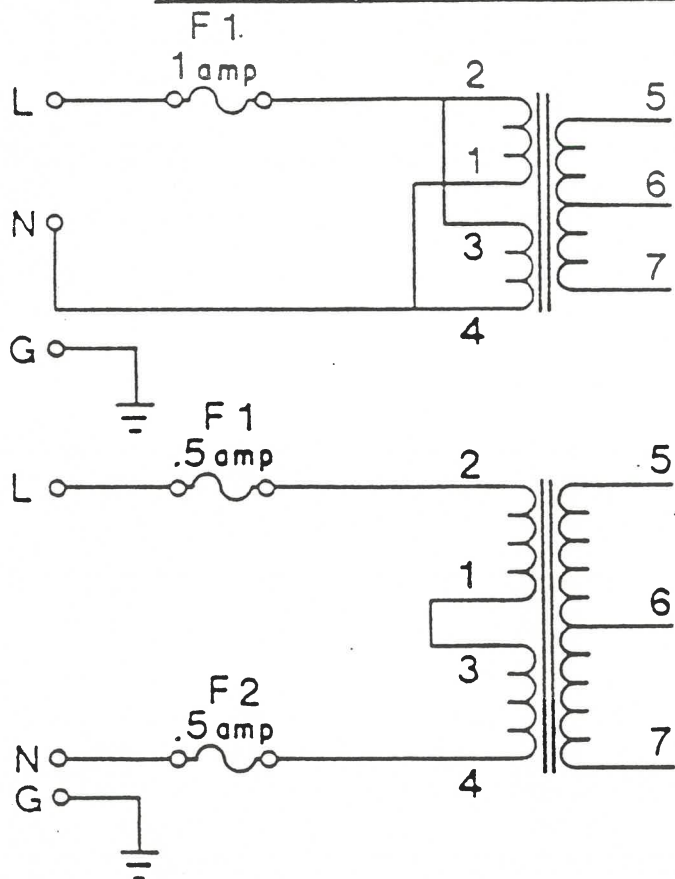

115 VOLT WIRING

220 VOLT WIRING



SECTION X

TECHNICAL SPECIFICATIONS

ELECTRICAL

Detectors

|                 |                                    |
|-----------------|------------------------------------|
| Frequency Range | 13.56 MHz (27.12 MHz Custom Basis) |
| Power Handling  | 500 Watt continuous                |
| Impedance       | 50 ohms                            |
| VSWR Introduced | Less than 1.1-1                    |

Tuning Network

|                  |                                    |
|------------------|------------------------------------|
| Frequency Range  | 13.56 MHz (27.12 MHz Custom Basis) |
| Power Handling   | 500 Watt continuous                |
| Input Impedance  | 50 ohms                            |
| Output Impedance | Wide range                         |

ELECTRICAL

|                    |                                    |
|--------------------|------------------------------------|
| Power Requirements | 220/115 VAC 50/60 Hz ±15VDC @ 1.5A |
| Power Consumption  | 45 W Maximum                       |

MECHANICAL

Power Supply

|        |                         |
|--------|-------------------------|
| Height | 1 3/4"                  |
| Width  | 8 1/2" (19" rack mount) |
| Depth  | 10"                     |

Tuning Network

|        |        |
|--------|--------|
| Height | 5"     |
| Width  | 8 3/4" |
| Depth  | 15"    |





SECTION XIRECOMMENDED SPARE PARTS LIST

## 11.1 CONTROLLER

| <u>NOMENCLATURE</u> | <u>DESCRIPTION</u>                      | <u>PART NUMBER</u> |
|---------------------|-----------------------------------------|--------------------|
| BR1                 | Bridge Rectifier MDA970-1               | 48100007           |
| C9, C10             | Electrolytic Capacitor 4700MFD @ 35V    | 15050035           |
| Q1, Q3              | Power Transistor T1P41                  | 48040034           |
| Q2, Q4              | Power Transistor T1P42                  | 48040035           |
| R30, R33            | Pot. 500 ohms Bourns #3299W-1-501       | 47100050           |
| R53, R58            | Pot. 500K ohms Bourns #3299X-1-504      | 47100053           |
| R65, 70, 78, 83     | Pot. 1K ohm Bourns #3299W-1-102         | 47100051           |
| U1, 2, 9, 10        | IC LM 324N                              | 48010011           |
| U3, 4, 7            | IC LM 339N                              | 48010021           |
| U5, 6, 13, 14       | IC CD4016B                              | 48010019           |
| U8                  | IC CD4011B                              | 48010051           |
| U11                 | IC CD4001                               | 48010018           |
| U12                 | IC CA3096AE                             | 48010062           |
| U15                 | IC LM358N                               | 48010015           |
| U16                 | IC CA3183E                              | 48010060           |
| U17                 | IC CA3141E                              | 48010061           |
| UR1                 | Voltage Regulator LM317T                | 48010012           |
| UR2                 | Voltage Regulator LM337T                | 48010059           |
| DS1-6               | LED Red GE#CM5754                       | 24040016           |
| S1                  | Toggle Switch 4PDT                      | 51020050           |
| S2, S4              | Toggle Switch SPDT                      | 51020051           |
| S3, S5              | Toggle Switch SPDT                      | 51020052           |
| T1                  | Power Supply Transformer                | 56010120           |
| F1                  | Fuse, 1 amp slo blo Little Fuse #313001 | 43080014           |



SECTION XIRECOMMENDED SPARE PARTS LIST (continued)

## 11.2 MATCHING NETWORK

| <u>NOMENCLATURE</u> | <u>DESCRIPTION</u>                                | <u>PART NUMBER</u> |
|---------------------|---------------------------------------------------|--------------------|
| A1C1                | Capacitor Air Variable Cardwell 154-33-1          | 15040013           |
| A1C2-A1C5           | Capacitor Ceramic 200pf @ 7.5KV                   | 15190010           |
| A1C6                | Capacitor Variable Vacuum<br>Jennings UCSL-500-5S | 15020004           |
| A1C7                | Capacitor Ceramic 1000pf @ 5KV                    | 15190006           |
| J3                  | Connector Type "HN"                               | 21020014           |
| A5M1, A4M1          | Motor Japanese Products #DME32BHP-12V             | 35010005           |
| A5 Assembly         | Gear Box Japanese Products #6H100                 | 35030002           |
| A4 Assembly         | Gear Box Japanese Products #6H1800                | 35030001           |
| A5R1                | Pot. 1K ohm Bourns #35415-1-102                   | 47100055           |
| A4R1                | Pot. 1K ohm Spectrol #132-0-0-102                 | 47100054           |
| A2CR1-A2CR4         | Diode IN38A                                       | 48020003           |
| A2C7, A2C8          | Capacitor Ceramic 5pf @ 5KV                       | 15190012           |
| A2F1                | Fuse .75 amp Little Fuse 318750                   | 43030009           |
| A2R1, A2R2          | Pot. 20K Bourns #3299-X-203                       | 47100019           |
| A2U1                | IC LM741                                          | 48010006           |
| A2ZD1, A2ZD2        | Diode Zener IN4743/13 volt                        | 48020029           |



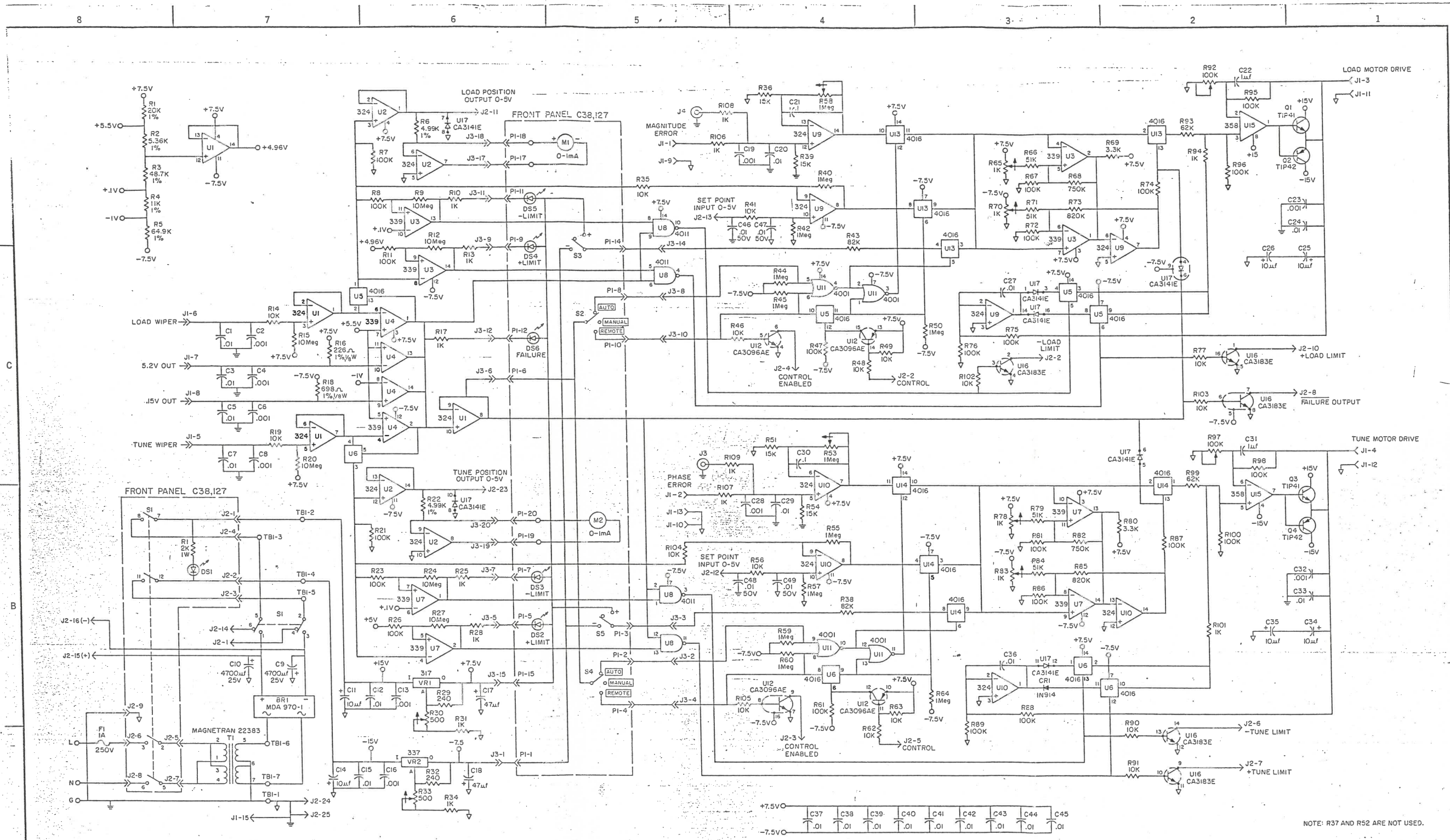

| REV. ZONE | DESCRIPTION                                    | DATE    | APPROVED  | REV. ZONE                                                                                                                                                                                                                                                        | DESCRIPTION            | DATE     | APPROVED |
|-----------|------------------------------------------------|---------|-----------|------------------------------------------------------------------------------------------------------------------------------------------------------------------------------------------------------------------------------------------------------------------|------------------------|----------|----------|
| M         | R6,22 WERE 5.1K/ECN 849 J1-15 GROUNDED ECN 842 | 6-25-71 | S. Deinas | E                                                                                                                                                                                                                                                                | REVISED PER ECN # 712  | 6-9-84   | JWP      |
| L         | REVISED PER ECN # M4650                        | 1-7-83  | J. Ponist | D                                                                                                                                                                                                                                                                | REVISED PER ECN # 898  | 5-10-84  | JWP      |
| K         | REVISED PER ECN # 513C                         | 7-8-86  | J. Ponist | C                                                                                                                                                                                                                                                                | REVISED PER ECN # 637  | 2-20-84  | HGF      |
| J         | REVISED PER ECN # M2780                        | 3-17-86 | JP        | B                                                                                                                                                                                                                                                                | RELEASED PER EPR # 014 | 12-9-84  | RAH      |
| I         | REVISED PER ECN # M1740                        | 11-5-85 | J. Ponist | A                                                                                                                                                                                                                                                                | PRELIMINARY RELEASE    | 10-14-83 | RAH      |
| H         | REVISED PER ECN # M1480T                       | 6-3-85  | JP        | REV. ZONE                                                                                                                                                                                                                                                        | DESCRIPTION            | DATE     | APPROVED |
| G         | REVISED PER ECN # M0730                        | 3-4-85  | JP        | THESE DRAWINGS AND SPECIFICATIONS ARE THE PROPERTY OF PLASMA-THERM, INC., N.J. AND SHALL NOT BE REPRODUCED, OR COPIED, OR USED AS THE DIRECT OR INDIRECT BASIS FOR THE MANUFACTURE, DEVELOPMENT, OR SALE OF APPARATUS, PROCESSES OR PRODUCTS WITHOUT PERMISSION. |                        |          |          |
| F         | REVISED PER ECN # M0640                        | 1-16-85 | JP        |                                                                                                                                                                                                                                                                  |                        |          |          |

NOTES:  
 1- Unless Otherwise Indicated, Resistance is in Ohms, 1/4 Watt Dissipation Rating, Fractional Values of Capacitance in Microfarads, All Others in Picofarads.



|                                        |  |                  |                              |  |
|----------------------------------------|--|------------------|------------------------------|--|
| DRAWN<br>NAL                           |  | DATE<br>10-14-83 | SUPERSEDES DWG. # 2403491201 |  |
| ENG APPVL<br>RAH                       |  | DATE<br>10-14-83 | RF Plasma Products, Inc.     |  |
| REL TO PROD                            |  | DATE             | TITLE<br>SCHEMATIC DIAGRAM   |  |
| NEXT ASSY USED ON<br>FIRST APPLICATION |  | REF. TO EPL      | MATCHING NETWORK CONTROLLER  |  |
| DWG. NO. 40,247                        |  | SHT 1 OF 1       | SIZE D                       |  |

\* NOTE:

FOR JAPANESE PRODUCTS MOTORS BLACK=+ RED=-

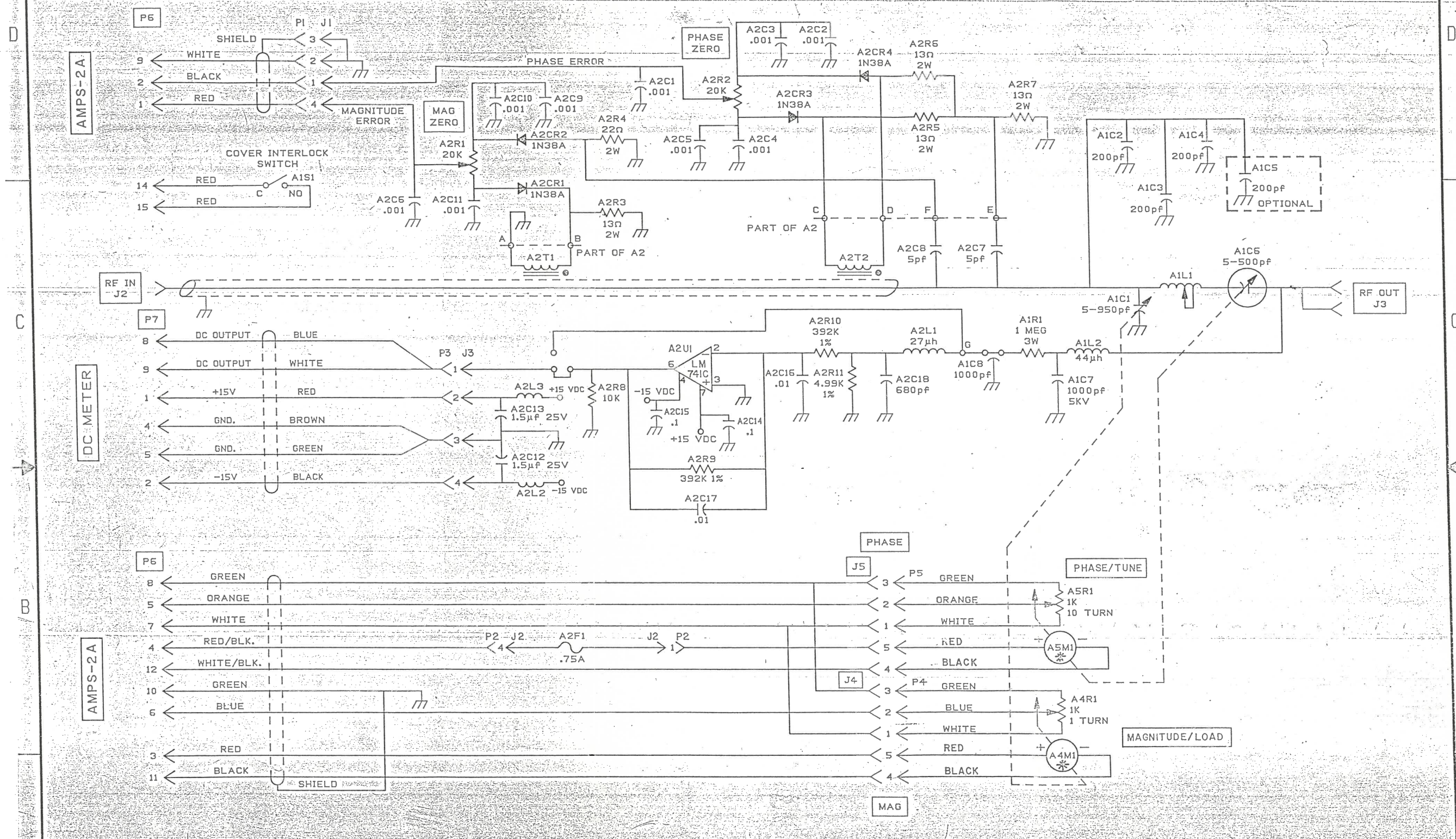

| REV                                                                                                                                                                                                                                                                      | ZONE | DESCRIPTION                     | DATE     | APPROVED | REV | ZONE | DESCRIPTION         | DATE    | APPROVED | NEXT ASSY.        | USED ON | DRWN    | DATE     | TITLE                                                       |      |   |
|--------------------------------------------------------------------------------------------------------------------------------------------------------------------------------------------------------------------------------------------------------------------------|------|---------------------------------|----------|----------|-----|------|---------------------|---------|----------|-------------------|---------|---------|----------|-------------------------------------------------------------|------|---|
| E                                                                                                                                                                                                                                                                        |      | REVISED PER ECN 795             | 4-9-91   | RIO      |     |      |                     |         |          |                   |         | BSR     | 09/16/85 | RF PLASMA PRODUCTS INC.                                     |      |   |
| D                                                                                                                                                                                                                                                                        |      | DELETED SHIELD - P3-3/ECN M4850 | 3-21-89  | RCW      |     |      |                     |         |          |                   |         |         | 9/18/85  | 22 OLNEY AVENUE CHERRY HILL, NEW JERSEY 08003 (609)424-7500 |      |   |
| C                                                                                                                                                                                                                                                                        |      | WAS AMN-502/ECN M3170           | 11-11-86 | RCW      |     |      |                     |         |          |                   |         |         | 9/18/85  | SCHEMATIC DIAGRAM                                           |      |   |
| B                                                                                                                                                                                                                                                                        |      | RELEASED PER EPR 0037           | 10/31/85 | RCW      |     |      |                     |         |          |                   |         |         | 9/18/85  | MATCHING NETWORK AM-5                                       |      |   |
| A                                                                                                                                                                                                                                                                        |      | PRELIMINARY                     | 9/18/85  | RCW      |     |      | REVISED PER ECN 834 | 8/26/91 | E. Demer | B23,407-000       | AM-5    |         | 11-1985  |                                                             |      |   |
| THESE DRAWINGS AND SPECIFICATIONS ARE THE PROPERTY OF R.F. PLASMA PRODUCTS, INC., N.J. AND SHALL NOT BE REPRODUCED, OR COPIED, OR USED AS THE DIRECT OR INDIRECT BASIS FOR THE MANUFACTURE, DEVELOPMENT, OR SALE OF APPARATUS, PROCESSES OR PRODUCTS WITHOUT PERMISSION. |      |                                 |          |          |     |      |                     |         |          |                   |         | DR. NO. | 30,187   | SHEET 1 OF 1                                                | SIZE | C |
| REVISIONS                                                                                                                                                                                                                                                                |      |                                 |          |          |     |      |                     |         |          | FIRST APPLICATION |         | USED ON | AM-5     | SCALE N/A                                                   |      |   |

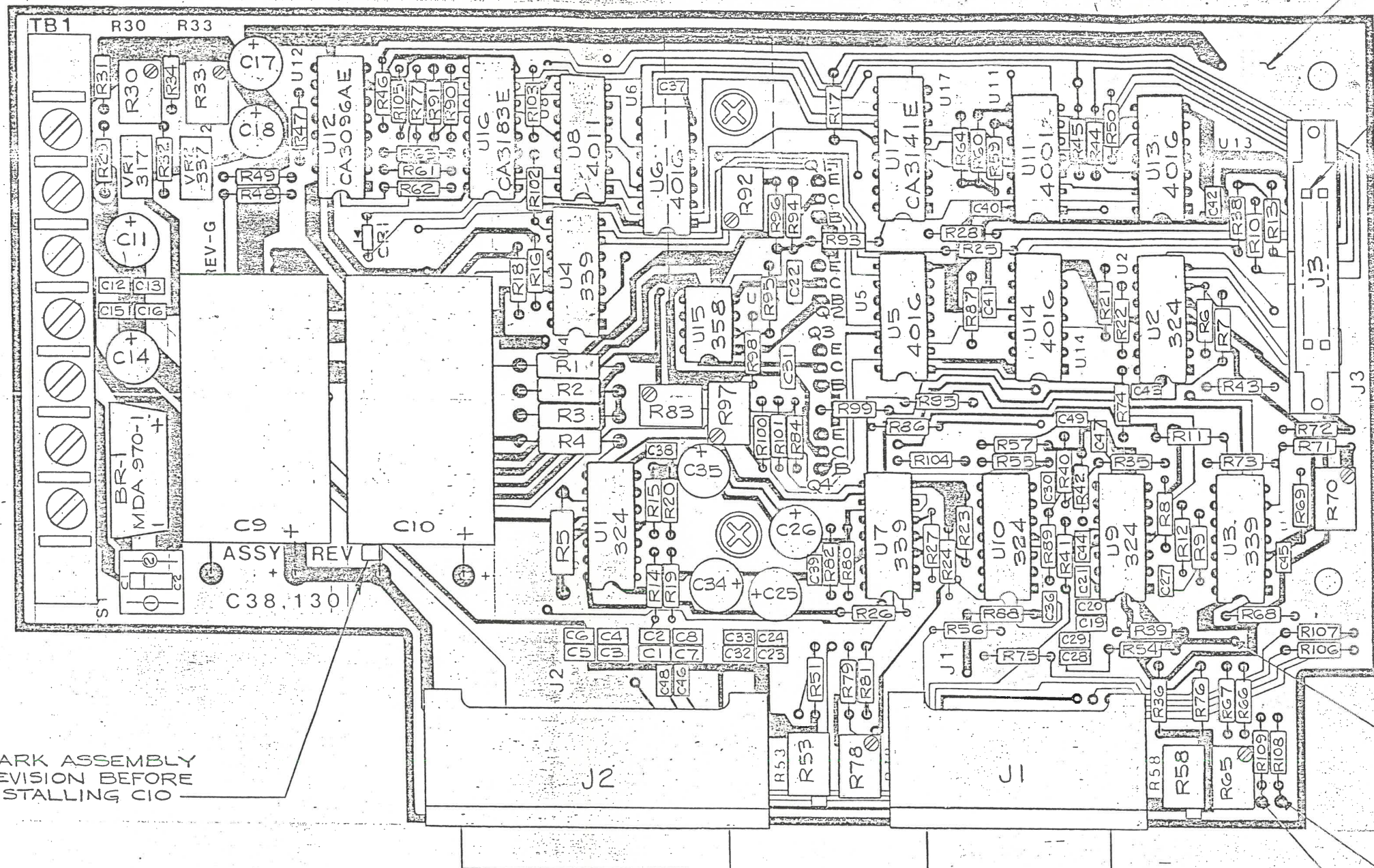

MARK ASSEMBLY  
REVISION BEFORE  
INSTALLING C10

QWD WIRE  
FROM BACK  
PANEL  
C38,131

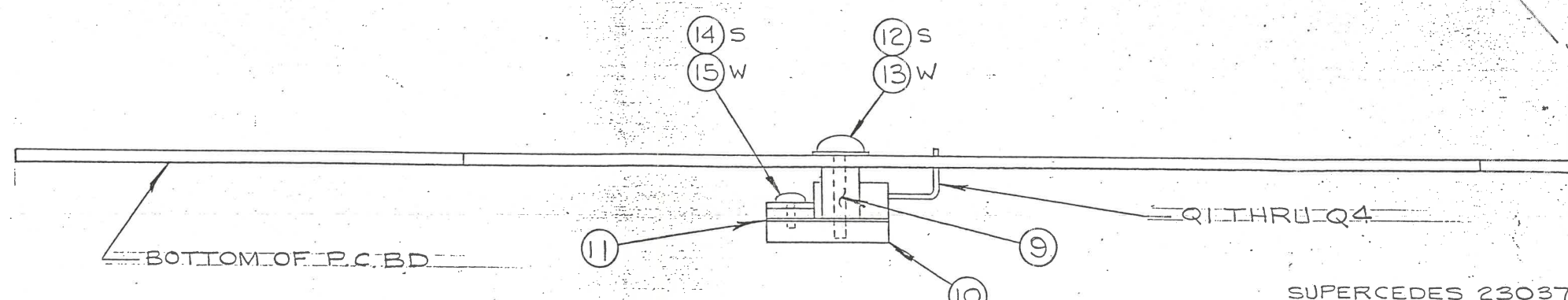

SUPERCEDES 2303750501

|           |   |                                    |      |          |         |                                                                         |                      |                                                                  |                    |                         |           |
|-----------|---|------------------------------------|------|----------|---------|-------------------------------------------------------------------------|----------------------|------------------------------------------------------------------|--------------------|-------------------------|-----------|
| REV. ZONE |   | DESCRIPTION                        | DATE | APPROVED | C38,131 | DRAWN<br>E D RAINIER 11-2-83<br>ENG APPVL<br>RAH 12-5-83<br>REL TO PROD | DATE<br>DATE<br>DATE | TITLE<br>PC ASSEMBLY<br>POWER SUPPLY<br>MATCHING NETWORK CONTROL | DWG. NO.<br>38,130 | SHT 1 OF 1<br>SCALE 2:1 | SIZE<br>C |
| 9         |   | REVISED & REDRAWN ECN 3000 5-22-83 |      |          |         | NEXT ASSY USED ON                                                       | REF. TO EPL          |                                                                  |                    |                         |           |
| PT-C2     | 4 |                                    |      |          | 3       | 2                                                                       |                      |                                                                  |                    | 1                       |           |

THESE DRAWINGS AND SPECIFICATIONS ARE THE PROPERTY OF PLASMA-THERM INC. N.J. AND SHALL NOT BE REPRODUCED OR COPIED, OR USED AS THE DIRECT OR INDIRECT BASIS FOR THE MANUFACTURE, DEVELOPMENT, OR SALE OF APPARATUS PROCESSES OR PRODUCTS WITHOUT PERMISSION.

Plasma-Therm, Inc.

| REVISIONS |                                 |          |             |
|-----------|---------------------------------|----------|-------------|
| LTR       | DESCRIPTION                     | DATE     | APPROVED    |
| A         | RELEASED PER EPR 0037           | 12/2/85  | [Signature] |
| B         | USED ON WAS AMN-502 / ECU M3170 | 11/11/86 | [Signature] |

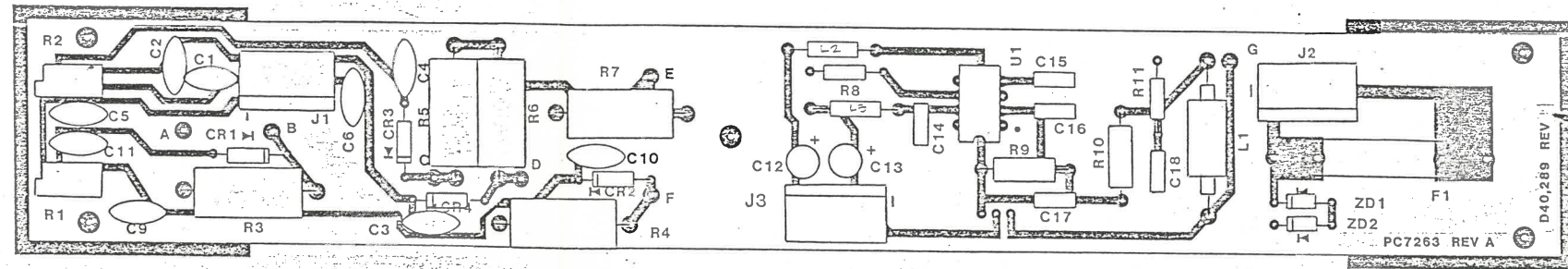

PRODUCTION TO MARK  
ASSEMBLY REVISION LETTER  
WITH PERMANENT BLACK INK

REF: EPL - 922 A01-002  
USED ON: AM-5

|                                                                                                                          |                        |                              |                                                                       |
|--------------------------------------------------------------------------------------------------------------------------|------------------------|------------------------------|-----------------------------------------------------------------------|
| UNLESS OTHERWISE SPECIFIED<br>DIMENSIONS ARE IN INCHES<br>TOLERANCES ARE:<br>FRACTIONS DECIMALS ANGLES<br>XX .XX .XX .XX |                        | CONTRACT NO.<br><b>85369</b> | CUSTOMER:<br><b>RF PLASMA</b>                                         |
| MATERIAL                                                                                                                 | APPROVALS              | DATE                         | BOARD TITLE:<br><b>AM-5 MATCHING NETWORK<br/>PCB ASSEMBLY DRAWING</b> |
| FINISH                                                                                                                   | DRAWN<br><i>BANK</i>   | 5/28/85                      | SIZE FSCM NO. DWG. NO.<br><b>D 62116 D40,289</b>                      |
| DO NOT SCALE DRAWING                                                                                                     | CHECKED<br><i>B.Em</i> | 5/17/85                      | SCALE 2:1 SHEET 1/1                                                   |



| REVISIONS |      |                                       |               |
|-----------|------|---------------------------------------|---------------|
| REV       | ZONE | DESCRIPTION                           | DATE APPROVED |
| A         |      | RELEASED PER EPR 0037                 | 10/1/85       |
| B         |      | ADDED TABULATION "A" CHANGED DETAIL B | 11/1/85       |
| C         |      | WAS AMN-502 / ECN M 5170              | 11/1/85       |

| PART | ASSEMBLY USAGE |
|------|----------------|
| 001  | HN CONNECTOR   |
| 002  | C CONNECTOR    |

TABULATION "A"

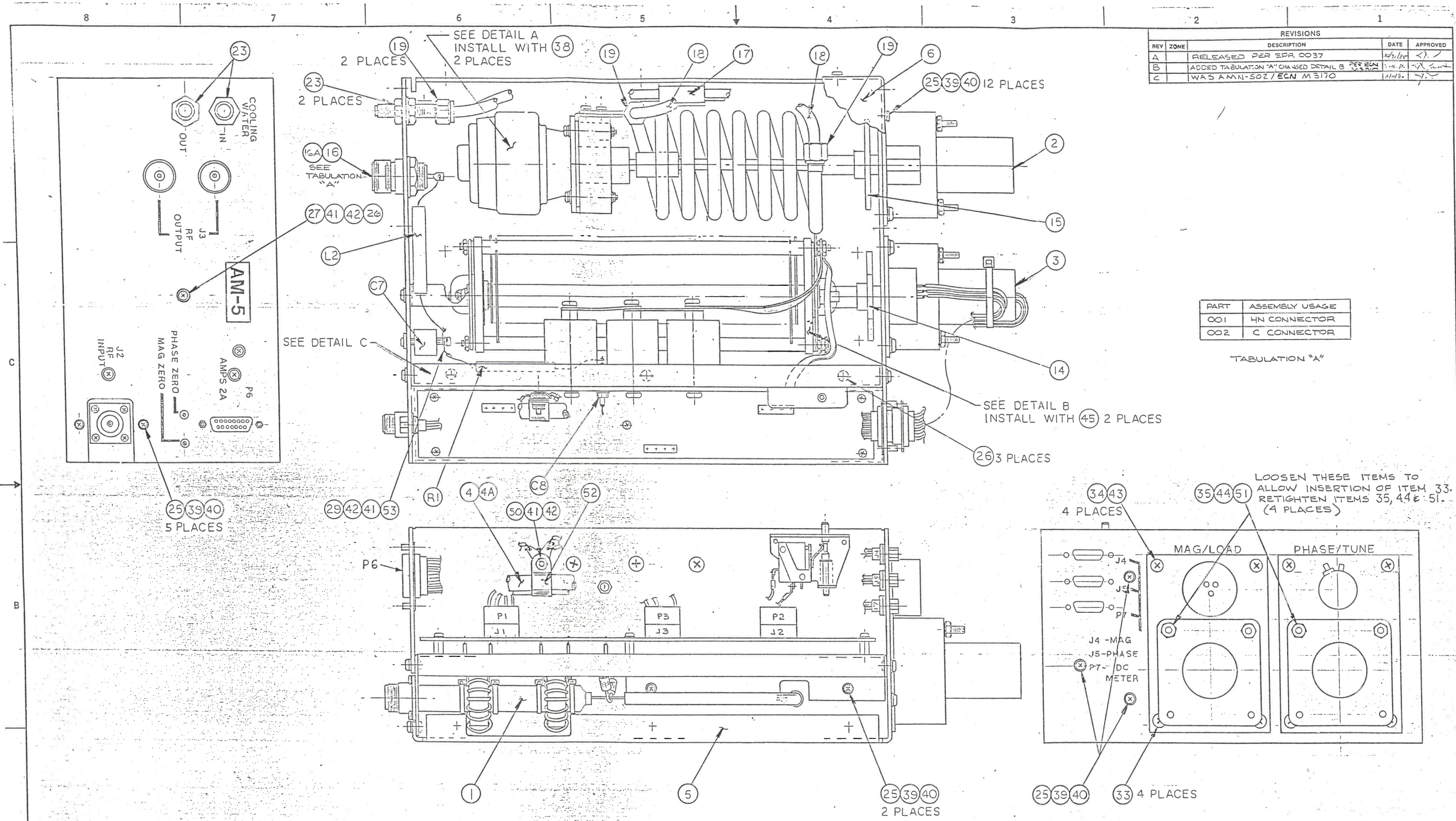

LOOSEN THESE ITEMS TO ALLOW INSERTION OF ITEM 33. RETIGHTEN ITEMS 35, 44 & 51. (4 PLACES)

|                                                                                                                                    |                                                                                      |                  |                                           |                                                                                            |                                     |
|------------------------------------------------------------------------------------------------------------------------------------|--------------------------------------------------------------------------------------|------------------|-------------------------------------------|--------------------------------------------------------------------------------------------|-------------------------------------|
| UNLESS OTHERWISE SPECIFIED THE SURF. FIN. OF MACHINED PARTS SHALL NOT EXCEED A MAX READING OF 1/16" PER AMERICAN STD. B46.1 - 1962 | UNLESS OTHERWISE SPECIFIED DIMENSIONS ARE IN INCHES AND INCLUDE THICKNESS OF PLATING |                  | DRAWN <i>A.F. GEN</i> DATE <i>5-28-85</i> | RF Plasma Products, Inc.<br>22 OLNEY AVENUE D CHERRY HILL, NEW JERSEY 08002 □ 609/424-7500 |                                     |
|                                                                                                                                    | TOLERANCES ON:                                                                       |                  | CHECKED <i>[Signature]</i> DATE           |                                                                                            |                                     |
|                                                                                                                                    | BASIC DIMENSIONS                                                                     | 2 PLACE DECIMALS | 3 PLACE DECIMALS                          |                                                                                            | ENG. APPVL <i>[Signature]</i> DATE  |
|                                                                                                                                    | UP TO 6                                                                              | ± .02            | ± .005                                    |                                                                                            | REL TO PROD <i>[Signature]</i> DATE |
| 6 TO 24                                                                                                                            | ± .03                                                                                | ± .010           |                                           |                                                                                            |                                     |
| ABOVE 24                                                                                                                           | ± .06                                                                                | ± .015           |                                           |                                                                                            |                                     |
| ANGULAR DIMENSIONS ± 1/2°                                                                                                          |                                                                                      | MFG. SPEC. NO.   |                                           |                                                                                            |                                     |
| DASH NO.                                                                                                                           | MATERIAL                                                                             | FINISH           | SPEC.                                     |                                                                                            |                                     |
|                                                                                                                                    |                                                                                      |                  |                                           |                                                                                            |                                     |
| LIST OF SPECIFICATIONS                                                                                                             |                                                                                      |                  |                                           |                                                                                            |                                     |
| DASH NO. <i>B23407-000</i> AM-5                                                                                                    |                                                                                      |                  |                                           |                                                                                            |                                     |
| NEXT ASSY USED ON                                                                                                                  |                                                                                      |                  |                                           |                                                                                            |                                     |
| FIRST APPLICATION                                                                                                                  |                                                                                      |                  |                                           |                                                                                            |                                     |
| SIZE NO.                                                                                                                           | D <i>D44478</i>                                                                      |                  |                                           |                                                                                            |                                     |
| SCALE                                                                                                                              | WEIGHT                                                                               |                  |                                           | SHEET 1 OF 2                                                                               |                                     |

THESE DRAWINGS AND SPECIFICATIONS ARE THE PROPERTY OF PLASMA-THERM, INC., N.J. AND SHALL NOT BE REPRODUCED, OR COPIED, OR USED AS THE DIRECT OR INDIRECT BASIS FOR THE MANUFACTURE, DEVELOPMENT, OR SALE OF APPARATUS, PROCESSES OR PRODUCTS WITHOUT PERMISSION.

BRUNING 44131 55171

PT-01

| REVISIONS |      |             |      |          |
|-----------|------|-------------|------|----------|
| REV       | ZONE | DESCRIPTION | DATE | APPROVED |
|           |      |             |      |          |
|           |      |             |      |          |

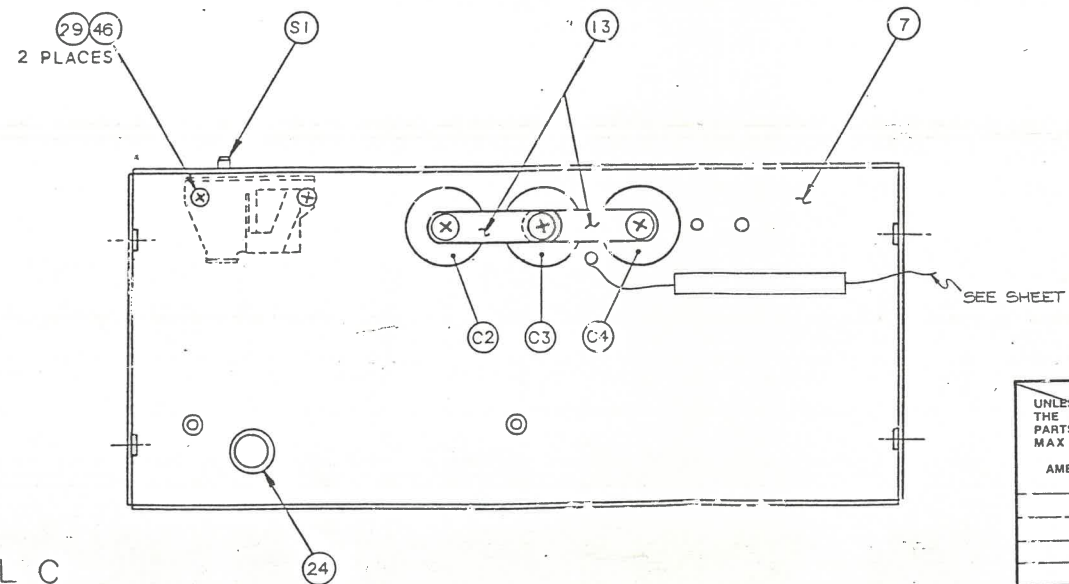
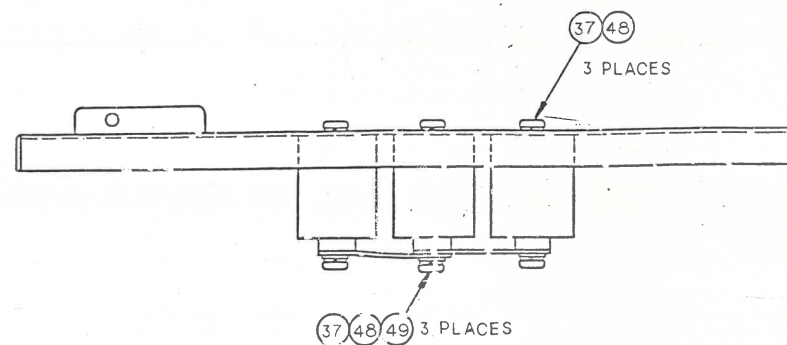
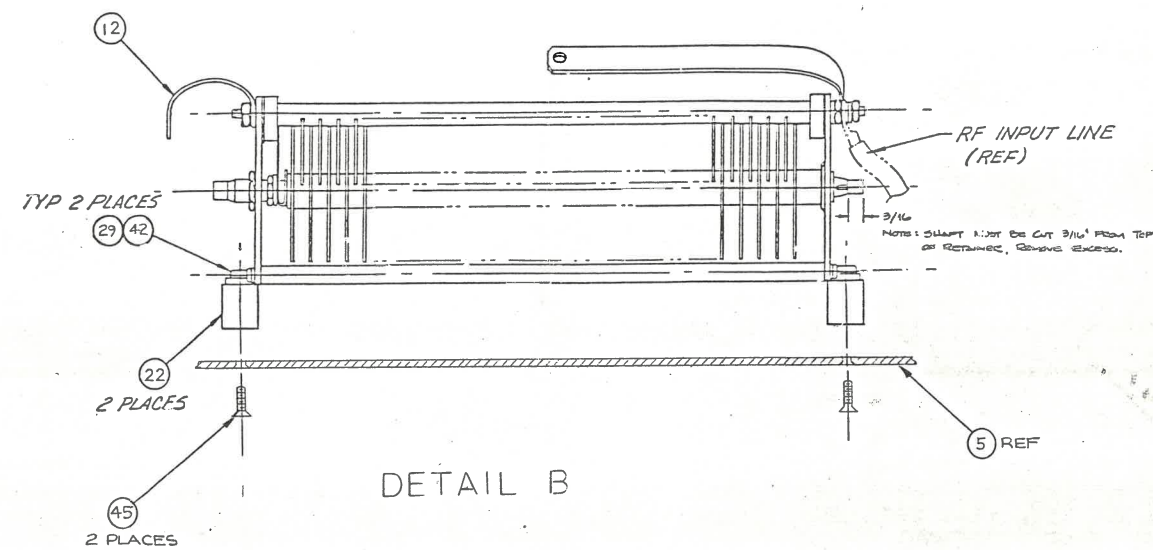
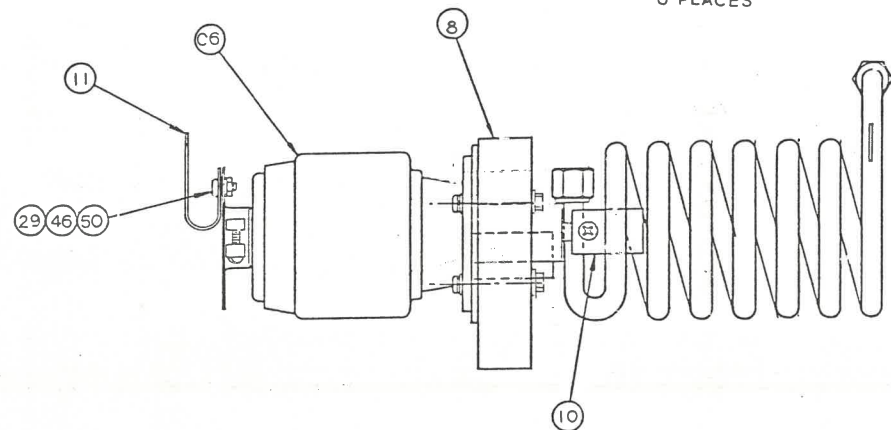
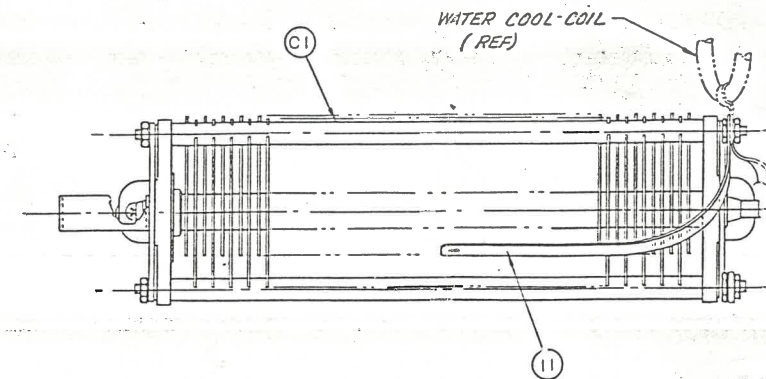
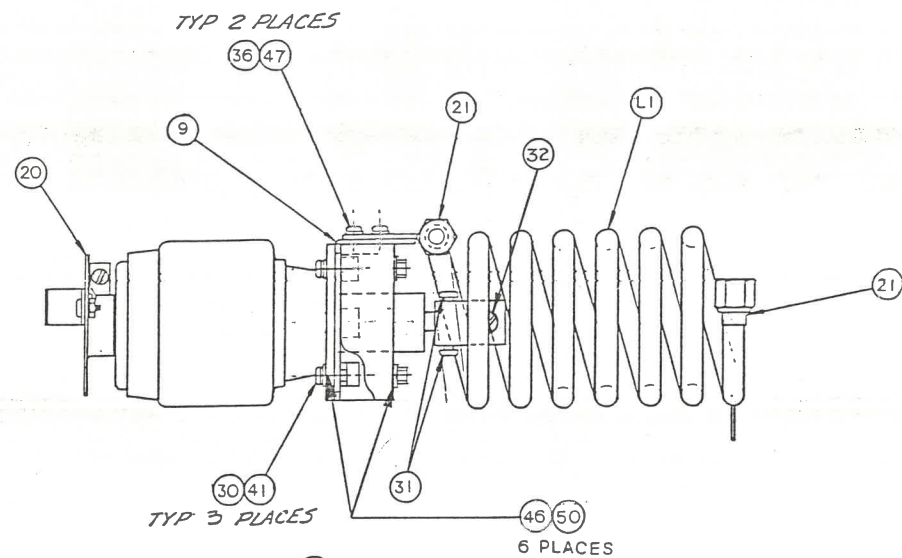

DETAIL A

DETAIL B

DETAIL C

THESE DRAWINGS AND SPECIFICATIONS ARE THE PROPERTY OF PLASMA-THERM, INC., N.J. AND SHALL NOT BE REPRODUCED, OR COPIED, OR USED AS THE DIRECT OR INDIRECT BASIS FOR THE MANUFACTURE, DEVELOPMENT, OR SALE OF APPARATUS, PROCESSES OR PRODUCTS WITHOUT PERMISSION.

LIST OF SPECIFICATIONS

|                                                                                                                                  |                                                                                                                                                                                                                                      |                              |                                                                                                   |                 |
|----------------------------------------------------------------------------------------------------------------------------------|--------------------------------------------------------------------------------------------------------------------------------------------------------------------------------------------------------------------------------------|------------------------------|---------------------------------------------------------------------------------------------------|-----------------|
| UNLESS OTHERWISE SPECIFIED THE SURFINISH OF MACHINED PARTS SHALL NOT EXCEED A MAX READING OF 125 PER AMERICAN STD • B46.1 • 1962 | UNLESS OTHERWISE SPECIFIED DIMENSIONS ARE IN INCHES AND INCLUDE THICKNESS OF PLATING<br>TOLERANCES ON:<br>5. SIC DIMENSIONS<br>UP TO 6 ± .02<br>ABOVE 6 TO 24 ± .03<br>ABOVE 24 ± .06<br>ANGULAR DIMENSIONS ± 1/2°<br>MFG. SPEC. NO. | DRAWN _____ DATE _____       | <b>RF Plasma Products, Inc.</b><br>22 OLNEY AVENUE □ CHERRY HILL, NEW JERSEY 08003 □ 609/424-7500 |                 |
|                                                                                                                                  |                                                                                                                                                                                                                                      | CHECKED _____ DATE _____     |                                                                                                   | TITLE _____     |
|                                                                                                                                  |                                                                                                                                                                                                                                      | ENG. APPVL _____ DATE _____  |                                                                                                   | SIZE NO. _____  |
|                                                                                                                                  |                                                                                                                                                                                                                                      | REL TO PROD _____ DATE _____ |                                                                                                   | D <b>D44478</b> |
| NEXT ASSY _____ USED ON _____ FIRST APPLICATION _____                                                                            | SCALE <i>N</i> WEIGHT _____ SHEET 2 OF 2                                                                                                                                                                                             |                              |                                                                                                   |                 |

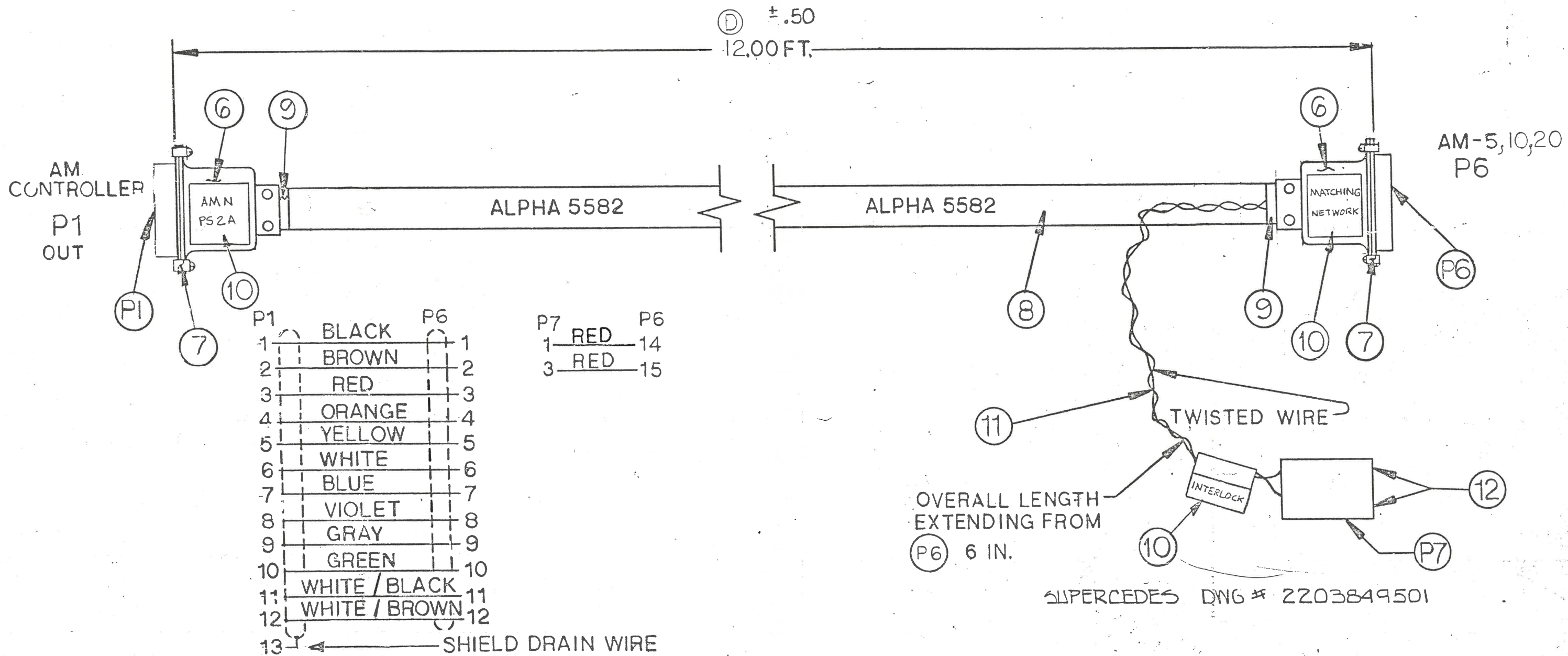

SUPERCEDES DNG # 2203849501

|                                                                                                                                                                                                                                                                  |      |                       |         |                  |            |                                                              |             |          |            |      |
|------------------------------------------------------------------------------------------------------------------------------------------------------------------------------------------------------------------------------------------------------------------|------|-----------------------|---------|------------------|------------|--------------------------------------------------------------|-------------|----------|------------|------|
|                                                                                                                                                                                                                                                                  |      |                       |         | DRAWN            | DATE       | Plasma-Therm, Inc.                                           |             |          |            |      |
|                                                                                                                                                                                                                                                                  |      |                       |         | R. MEROLA        | 10-31-85   |                                                              |             |          |            |      |
|                                                                                                                                                                                                                                                                  |      |                       |         | ENG APPV         | DATE       | TITLE                                                        |             |          |            |      |
|                                                                                                                                                                                                                                                                  |      |                       |         |                  | 11-1-85    | ASSEMBLY,<br>INTERCONNECT CABLE,<br>AM CONTROLLER-AM-5/10/20 |             |          |            |      |
|                                                                                                                                                                                                                                                                  |      |                       |         | REL TO PROD      | DATE       |                                                              |             |          |            |      |
|                                                                                                                                                                                                                                                                  |      |                       |         |                  | 11-1-85    |                                                              |             |          |            |      |
| REV.                                                                                                                                                                                                                                                             | ZONE | DESCRIPTION           | DATE    | APPROVED         | NEXT ASSY  | USED ON                                                      | REF. TO EPL | DWG. NO. | SHT 1 OF 1 | SIZE |
| E                                                                                                                                                                                                                                                                |      | ADDED LABELS ECN 6960 | 4-23-90 | <i>P. Merola</i> | 200785650X | AM10/20                                                      | B23,407-008 | 28,138   | SCALE      | B    |
| THESE DRAWINGS AND SPECIFICATIONS ARE THE PROPERTY OF PLASMA-THERM, INC., N.J. AND SHALL NOT BE REPRODUCED, OR COPIED, OR USED AS THE DIRECT OR INDIRECT BASIS FOR THE MANUFACTURE, DEVELOPMENT, OR SALE OF APPARATUS, PROCESSES OR PRODUCTS WITHOUT PERMISSION. |      |                       |         |                  |            |                                                              |             |          |            |      |
| FIRST APPLICATION                                                                                                                                                                                                                                                |      |                       |         |                  |            |                                                              |             |          |            |      |